

## K10143 Air Conditioner Bracket Kit for LSx Corvette engines

### Kit contents:

- Front and rear compressor attachment plates.
- Water pump brace plate.
- Aluminum spacer tubes and idler pulley mount
- Idler pulley, Gates 38012 or equivalent.
- All fasteners required to mount bracket to engine, and compressor to bracket

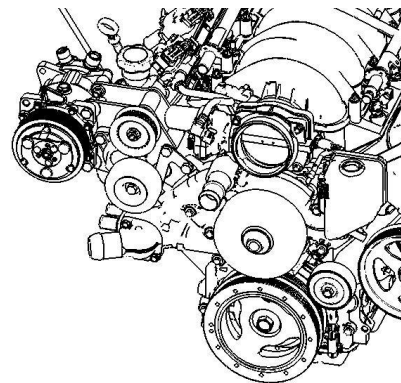

### In addition, the following parts are required:

- LS2 main belt tensioner, GM part number 12569301 or equivalent. Use your existing Corvette tensioner or request the tensioner for a 2005 Corvette.
- Air conditioner compressor, Sanden “508” style, current model number is SD5H14. The most popular configuration used by most all aftermarket AC makers is the “6629” which indicates it has a 7-groove serpentine pulley and 3/4” and 7/8” O-ring ports pointing upward. We offer this pump on the Accessories page of our web site: <http://kwikperf.com/accessories.html> .
- If using a Kwik Performance alternator bracket, use the belt suggested in the alternator bracket instructions. If using the factory Corvette alternator bracket, use a six-rib belt, length about 101”, so that the tensioner indicator arrow is between the max and min marks. Gates part number K061005 (101 1/8”) is suggested.

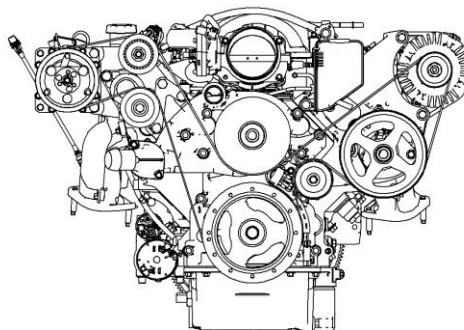
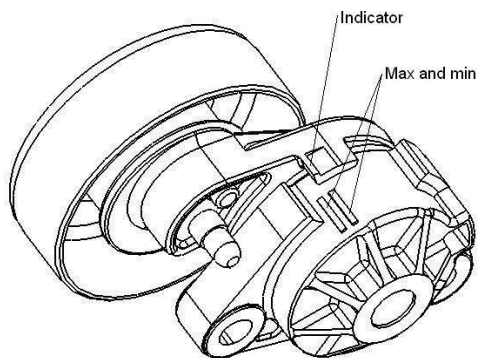

### Pre-installation

Before installing the brackets, the tensioner must be modified. Remove the six-groove pulley, which will be used as the idler pulley. The smooth idler pulley listed above will be used on the tensioner, and should be installed after all bolts are installed to make the 90mm bolts easier to install. Leave the nut holding the 6-groove pulley loose until after the 38012 pulley is secured to prevent flange interference. Push the tensioner arm down if necessary to tighten the 6-groove pulley nut.

### Notes

- Install the 130mm idler bolt from the rear, because the flange nut must be placed against the idler pulley. This must be done before bolting any brackets in place, or the bolt will not clear the valve cover. The bearing cover can be used or discarded.
- Shim plate under tensioner lower boss counteracts play in the tensioner pivot.
- **Some water pumps require a 3/8” washer to be installed between the L-plate and main plate.**
- **Leave all bolts loose until all parts are installed. Lift up on the front of the compressor when tightening the bolts. Tighten first the 2 bolts that screw into the head to square up the plates, then tighten the 2 bolts that screw into the water pump. After that, the bolts may be tightened in any order.**
- Torque all 10mm bolts to 37 ft-lbs (50 N-m), and torque the 12mm bolt to 50 ft-lbs (68 N-m).
- The belt is installed on the forward 6 grooves of the 7-groove compressor pulley.
- **Install the 16mm washer on the tensioner under the smooth 38012 pulley for alignment.**

K10143  
A/C Bracket for LS1 LSx Corvette  
Installation Instructions

**Kwik**  
Performance, Inc.  
www.kwikperf.com

1. Assemble idler pulley.

Remove bearing cover if desired for max thread engagement.

Flange nut

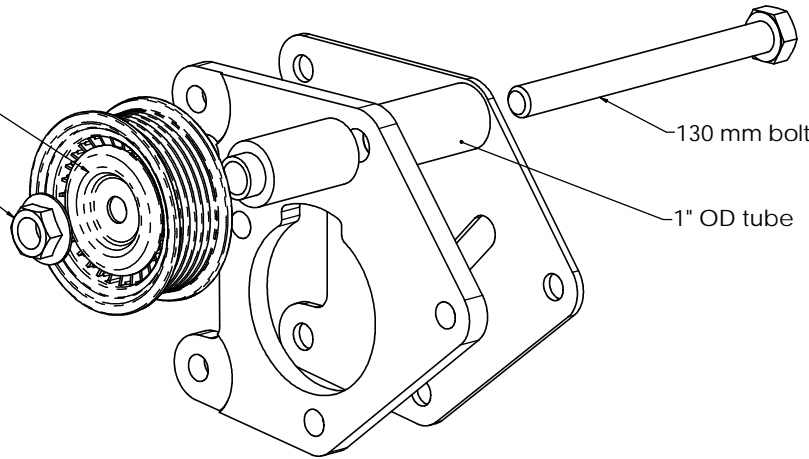

2. Install brackets

80mm bolt  
Screws into head

20mm bolts  
Screw into water pump

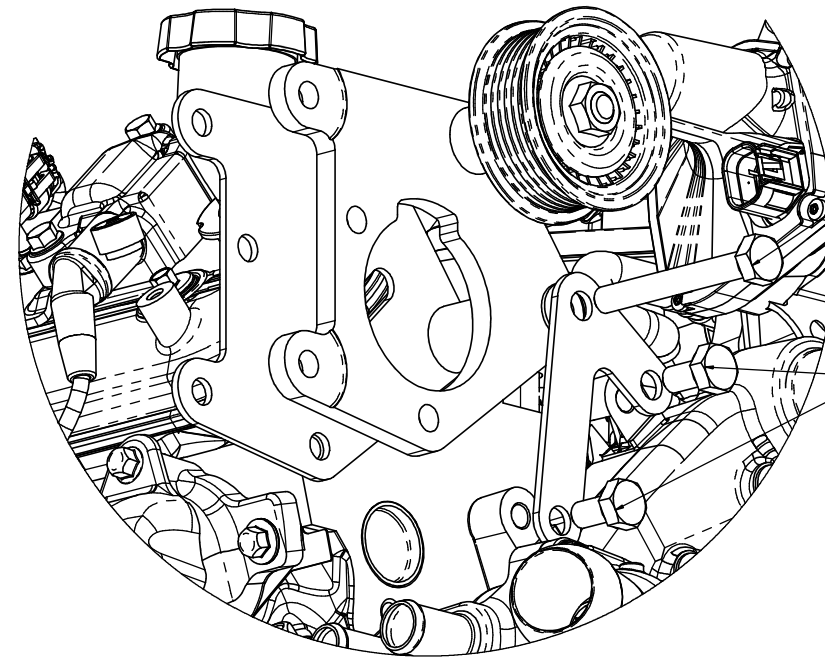

3. Install tensioner

90mm bolt

Flange nut

90mm bolt  
Screws into head

Install shim between tensioner and main plate

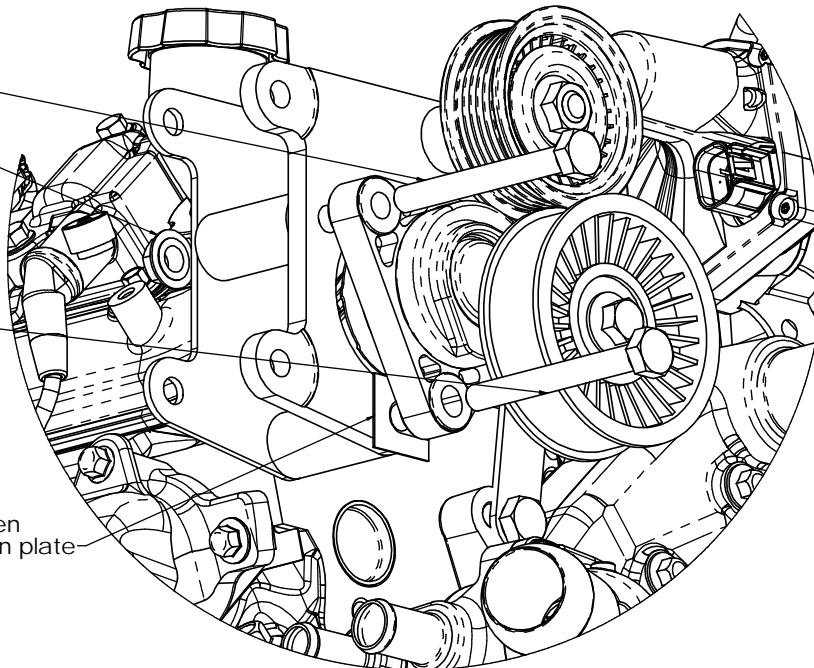

4. Install compressor

60mm bolts and flange nuts

3/4" OD tubes

35mm bolts and flange nuts

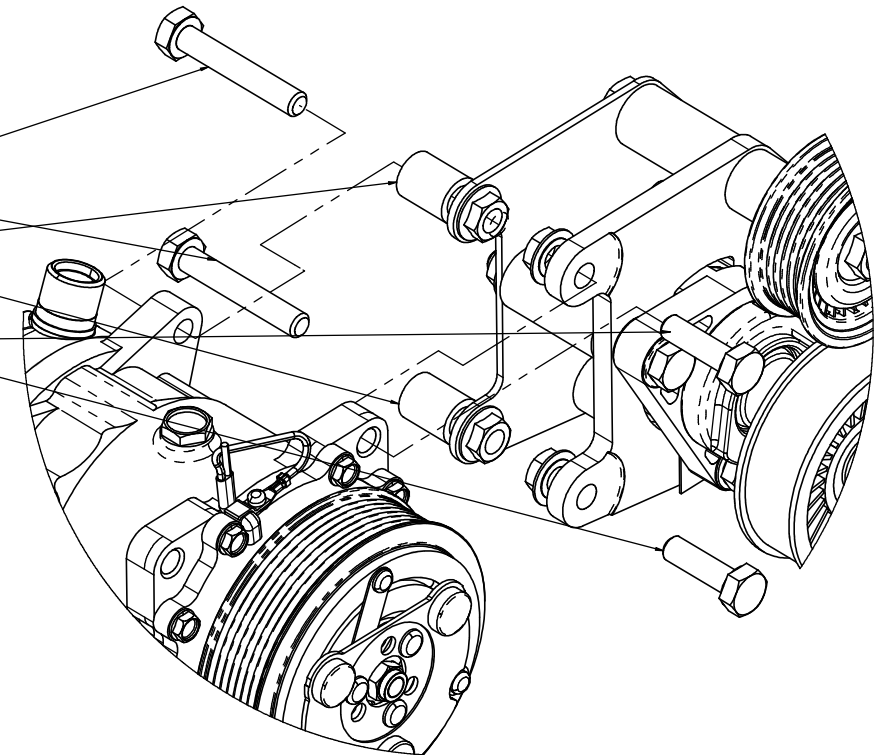

5. See page 1 for bolt tightening sequence.

Tighten 10mm fasteners to 37 ft-lbs (50 N-m), tighten 12mm fasteners to 50 ft-lbs (68 N-m).

## Adjustment Instructions

**KWiK**  
Performance, Inc.  
www.kwikperf.com

## A/C Compressor bracket for LSx engines

1. Due to variations in water pumps, a washer may be needed for proper alignment of the water pump brace.

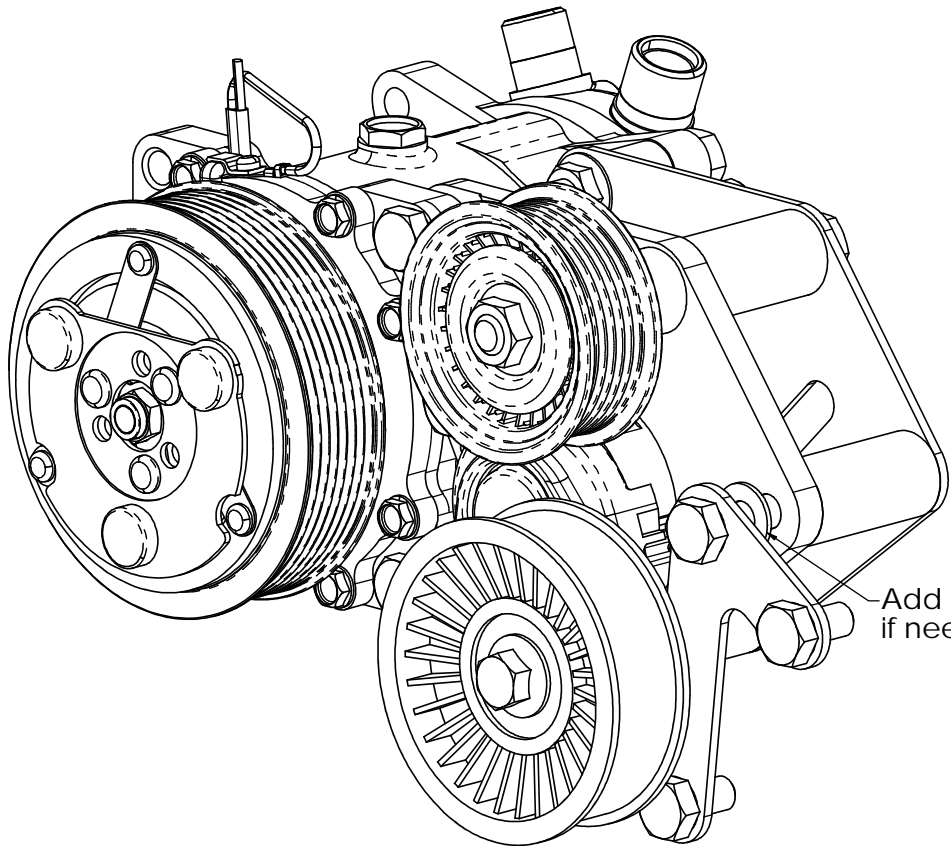

Add 3/8" washer  
if needed.

2. Leave all fasteners slightly loose until all parts are in place. Then lift up on the compressor pulley while tightening down the two bolts that screw into the cylinder head. This squares up the bracket to the head. Then tighten the water pump bolts, then the rest of the bolts.

3. Due to variations in tensioners, a washer may be needed for proper alignment of tensioner pulley 38001 or 38006. The back of the serpentine belt should run less than 1/8" from the back of the 38001 or 38006 pulley. Washer is always used with 38012 pulley to prevent interference between the pulley and the tensioner arm.

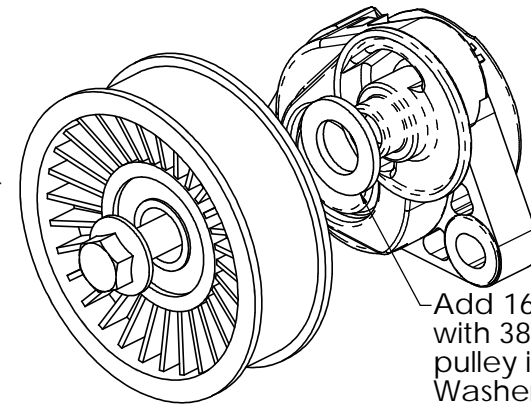

Add 16mm washer  
with 38001 or 38006  
pulley if needed.  
Washer must always  
be used with 38012  
pulley.