



## Installation Instructions for K10472

### A/C Bracket for truck or 5th gen Camaro LS engines

#### Kit contents:

- Mounting plates
- Spacer tubes
- Fasteners
- Idler pulley
- Tensioner

#### Additional parts required:

- Belt. See chart below.
- AC compressor, Sanden "508" style. Typical SD5 Sanden part number is 6629. However, we recommend the SD7 Sanden part number 4665 for smoother operation and less vibration.

Belt length and Gates PN - K10472 AC bracket - Truck (130+ amp alternator) and 2010+ Camaro spacing					
Factory GM truck Alt/PS bracket and pulley	Factory GM 2010+ Camaro Alt/PS bracket and pulley	Kwik Performance Alt/PS bracket K10168			Kwik Performance alternator only bracket K10195
		6.7" diameter power steering pulley	6.0" diameter power steering pulley	5.5" diameter power steering pulley	
112.88" K061123	102.6" K061020	98.13" K060975	97.13" K060966	96.88" K060962	91.25" K060909

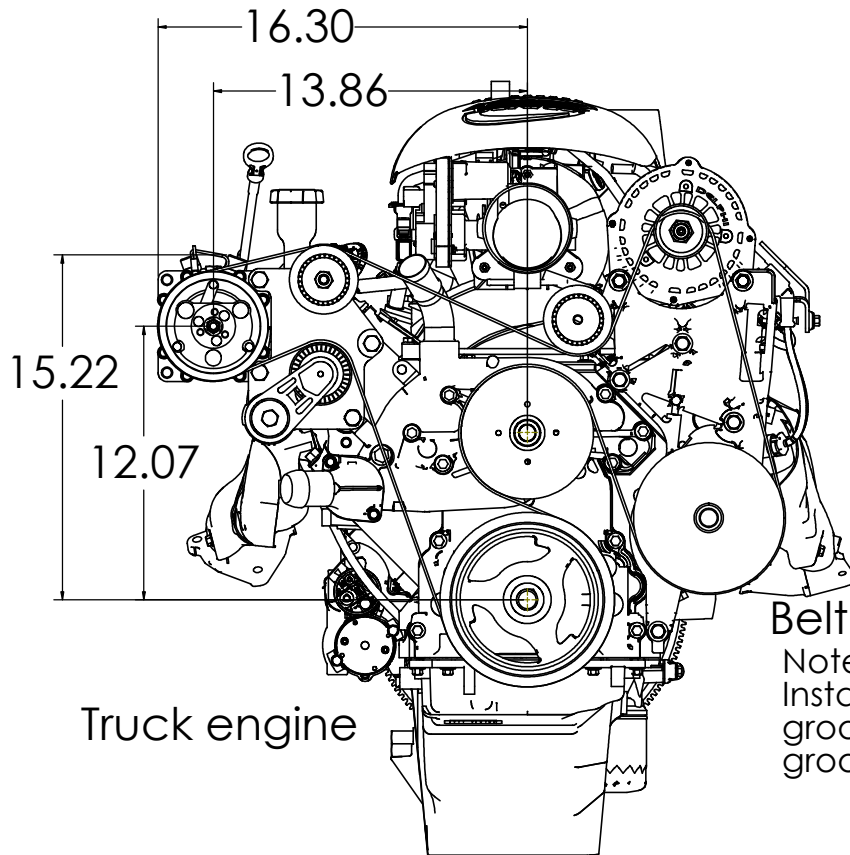

#### Belt installation

Note:  
Install belt in rear 6 grooves of the 7 groove compressor.

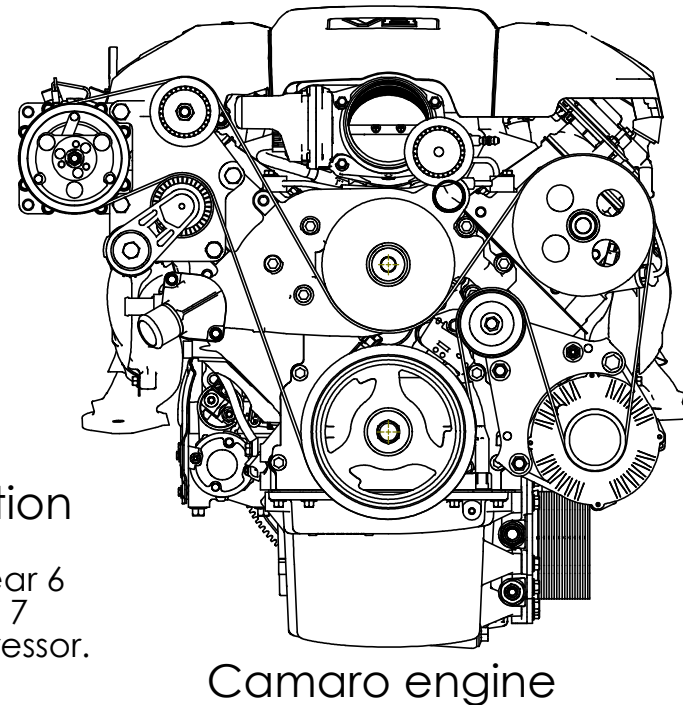



# Installation Instructions for K10472

A/C Bracket for LS engines  
with truck or 2010+ Camaro balancer

## 2. Install Water Pump Bolt

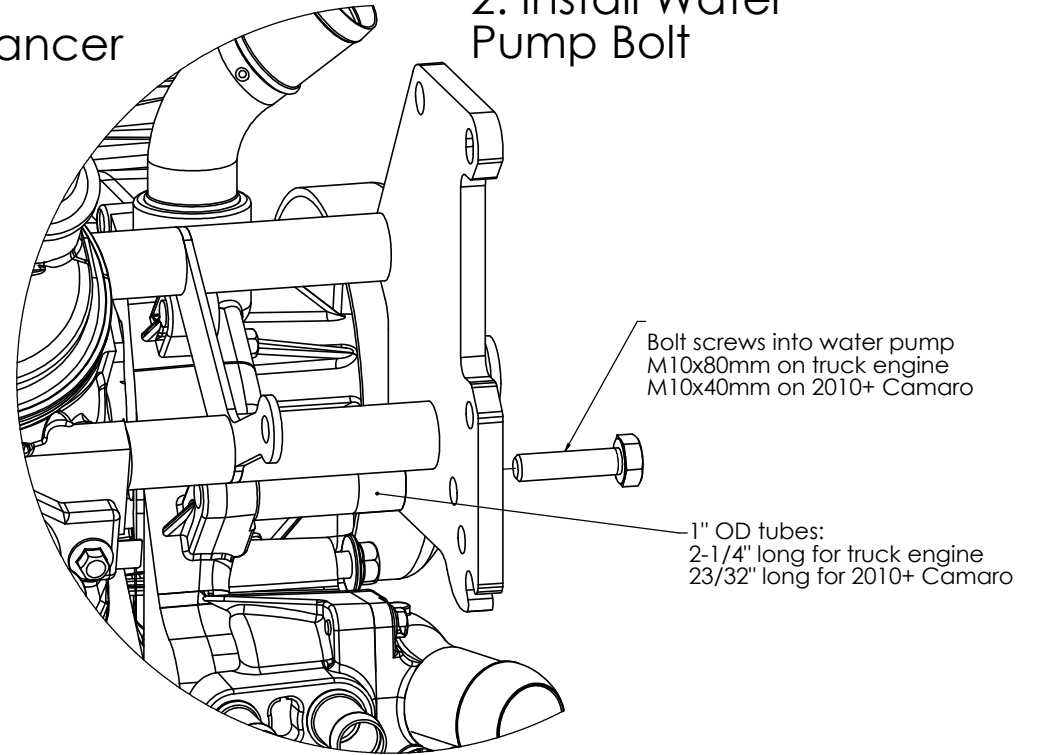
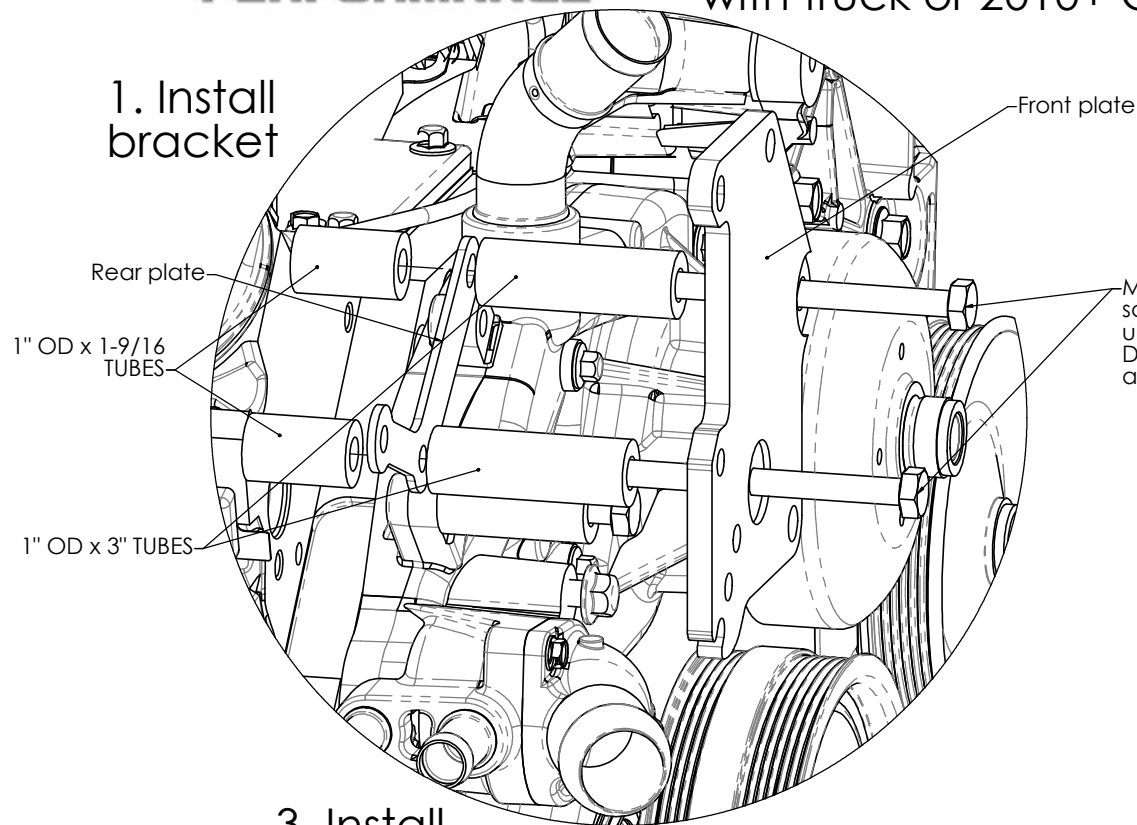

## 3. Install compressor

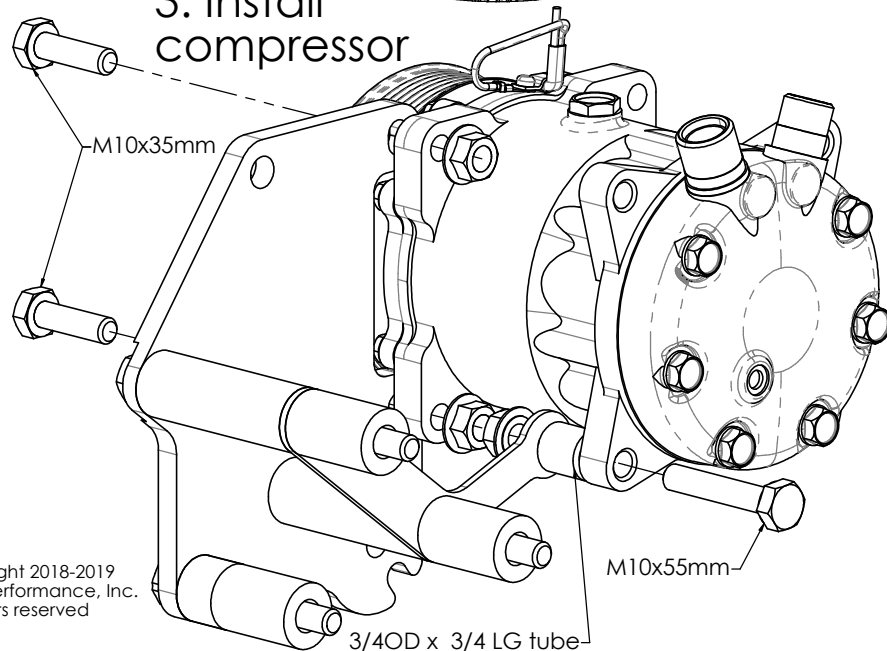

## 4. Install tensioner & idler pulley

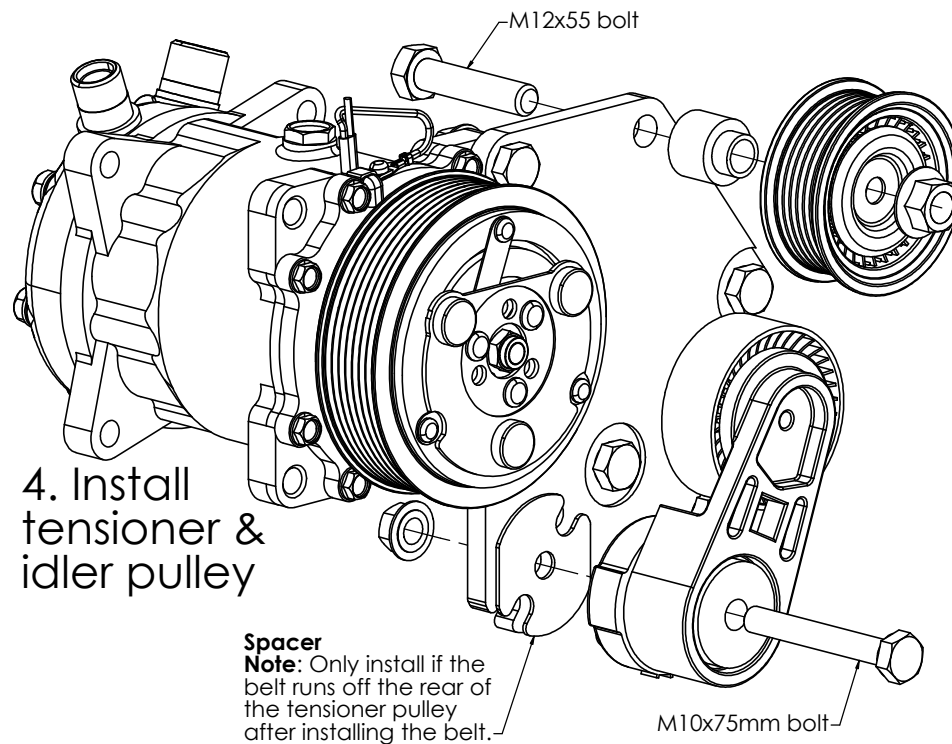

## 5. Tighten bolts.

Tighten 10mm fasteners to 37 ft-lbs (50 N-m), Tighten 12mm fasteners to 50 ft-lbs (68 N-m).

**Spacer**  
**Note:** Only install if the belt runs off the rear of the tensioner pulley after installing the belt.