

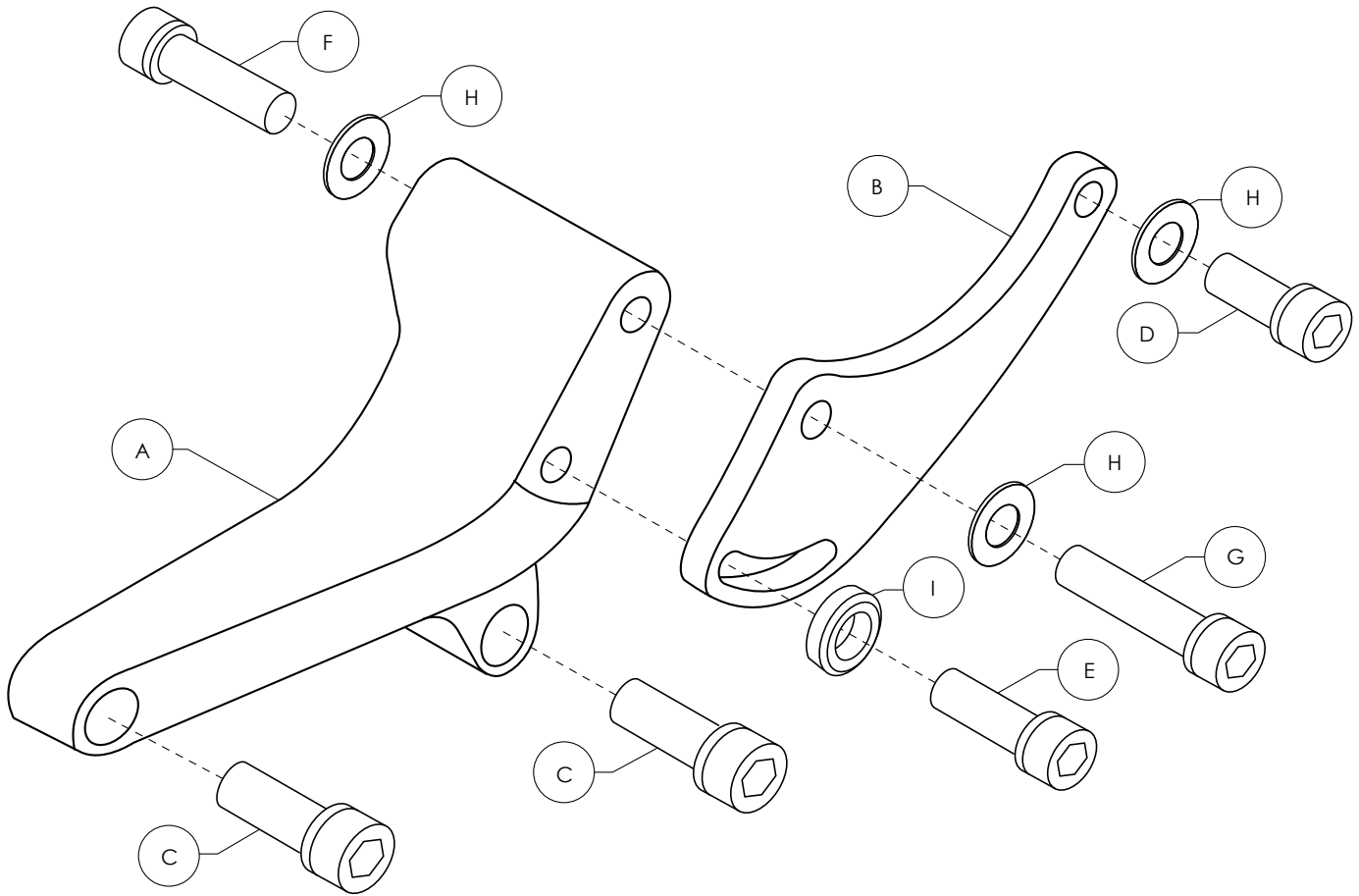

#10521 Compressor Bracket Mount Instructions Top Mount - Passenger Side



For use with:

- Chevy big block
- Short water pump
- Sanden 508 AC compressor

1. Use Loctite® removable threadlocker 242 (blue) on all fasteners.
2. Bolt compressor bracket [A] to passenger side head using bolts [C] 7/16-14 x 1-1/4" SHCS in two locations shown in illustration. Tighten.
3. Bolt adjustment arm [B] to compressor bracket [A] using bolt [E] 3/8-16 x 1-1/4" SHCS and [I] stainless load washer. Position adjustment arm with bolt location [G] aligned and bolt [E] at the center of the adjustment slot. Tighten bolt [E].
4. Install compressor on bracket [A-B] with the compressor fittings in the 11 and 12 o'clock position using bolt [D] 3/8-16 x 1" SHCS and [H] stainless flat washer, bolt [F] 3/8-16 x 1-1/2" SHCS and [H] stainless flat washer, and bolt [G] 3/8-16 x 1-3/4" SHCS and [H] stainless flat washer. Tighten bolt [D]. Do not fully tighten bolts [F] and [G].
5. Loosen bolt [E] 3/8-16 x 1-1/4" SHCS and allow compressor to rotate clockwise to allow installation of compressor belt.
6. Install compressor belt on front groove when using 2-groove pulleys.
Goodyear: #15550 Gates: #7545XL Belt: 7/16" x 54-1/2"
7. Apply tension on compressor belt and tighten bolts [E] 3/8-16 x 1-1/4" SHCS, [F] 3/8-16 x 1-1/2" SHCS, and [G] 3/8-16 x 1-3/4" SHCS.

BILL OF MATERIALS

ITEM	QTY.	DESCRIPTION	SIZE
A	1	Compressor Mounting Bracket	
B	1	Compressor Adjustment Arm	
C	2	7/16"-14 Socket Head Cap Screw	1-1/4"
D	1	3/8"-16 Socket Head Cap Screw	1"
E	1	3/8"-16 Socket Head Cap Screw	1-1/4"
F	1	3/8"-16 Socket Head Cap Screw	1-1/2"
G	1	3/8"-16 Socket Head Cap Screw	1-3/4"
H	3	Stainless Flat Washer	3/4" x .060"
I	1	Stainless Load Washer	3/4" x 3/16"